

ВЫВОДНОЙ СВЕТОДИОД КРУГЛЫЙ

ARL-5013RGBW-B-7color Slow

FEATURES

- Choice of various viewing angles.
- Available on tape and reel.
- Reliable and robust.
- Fast flash type.
- Pb free.

DESCRIPTIONS

- The series is specially designed for application requiring higher brightness.
- The LED lamps are available with different colors, intensity, epoxy colors etc.

APPLICATIONS

- TV set.
- Monitor.
- Telephone.

DEVICE SELECTION GUIDE

LED Part No.	CHIP		Lens Color
	Material	Emitted Color	
ARL-5013RGBW-B-7color Slow	AlGaInP	Red	White Diffused
	InGaN	Green	
	InGaN	Blue	



5 mm



DIFFUSED



RGB



USAGE NOTES:

The ultra bright LED is an electrostatic insensitive device, so static electricity and surge will damage the LED.

It is required to wear a wrist-band when handling the LED.

All device, equipment, machinery, desk and ground must be properly grounded.

When using LED, it must use a protective resistor in series with DC current about 20 mA.



ATTENTION!
ELECTROSTATIC SENSITIVE DEVICES.
OBSERVE PRECAUTIONS FOR HANDLING.

PACKAGE DIMENSIONS

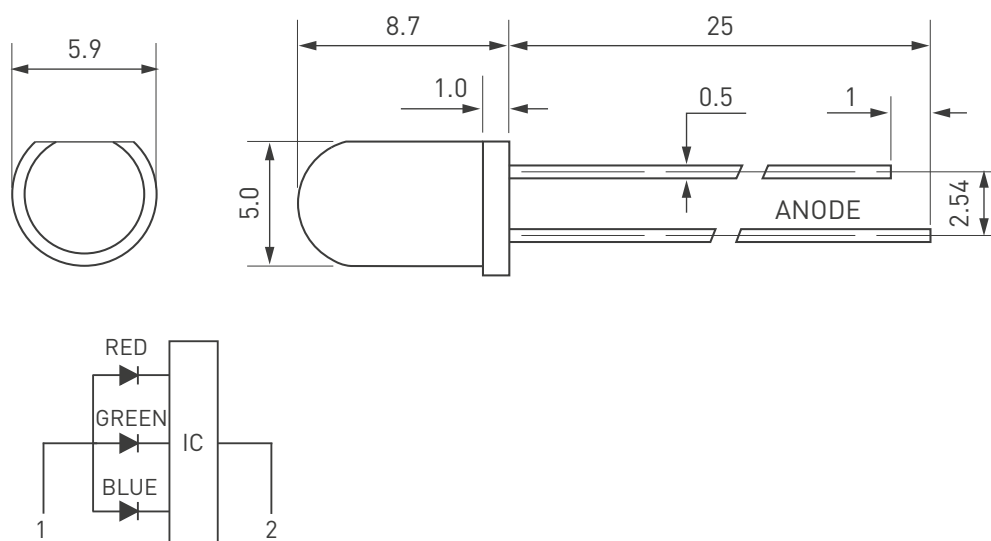

Unit: mm.

Notes:

Other dimensions are in millimeters, tolerance is 0.25 mm except being specified.

Protruded resin under flange is 1.5 mm Max LED.

Bare copper alloy is exposed at tie-bar portion after cutting.

ABSOLUTE MAXIMUM RATING ($T_A = +25^\circ\text{C}$)

Parameter	Symbol	Absolute Maximum Rating	Unit
Forward Pulse Current	I_{FPM}	100	mA
Forward Current	I_{FM}	30	mA
Reverse Voltage	V_R	5	V
Operating Temperature	T_{opr}	-40... +80	°C
Storage Temperature	T_{stg}	-40... +100	°C
Soldering Heat (5s)	T_{sol}	260	°C

ELECTRO-OPTICAL CHARACTERISTICS (T_A = +25 °C)

Parameter	Symbol	Device	Min.	Typ.	Max.	Unit	Test Condition
Luminous Intensity	I _v	Red	800	1000	1200	mcd	I _f =20mA
		Green	1000	1800	2000		
		Blue	800	1000	1200		
Viewing Angle	2θ _{1/2}	Red	—	25	30	Deg	(Note 1)
		Green					
		Blue					
Peak Emission Wavelength	λ _p	Red	—	630	—	nm	I _f =20mA
		Green	—	525	—		
		Blue	—	470	—		
Spectral Line Half-Width	Δλ	Red	—	20	—	nm	I _f =20mA
		Green	—	35	—		
		Blue	—	20	—		
Forward Voltage	V _F	Red	—	2.2	2.6	V	I _f =20mA
		Green	—	3.5	4.0		
		Blue	—	3.5	4.0		
Cycle	S		—	30	—	SEC	I _f =20mA

Note:

- Luminous intensity is measured with a light sensor and filter combination that approximates the CIE eye-response curve.
- θ_{1/2} is the off-axis angle at which the luminous intensity is half the axial luminous intensity.

TYPICAL ELECTRO-OPTICAL CHARACTERISTICS CURVES

Item	Test Conditions	Test Hours/Cycle	Sample Size	Ac/Re
Solder Heat	temp: 260 °C	5 sec	76 PCS	0/1
Temperature Cycle	H: +85 °C — 30 min J 5 min L: - 55 °C — 30 min	50 cycles	76 PCS	0/1
Thermal Shock	H: +100 °C — 5 min J 10 set L: -10 °C — 5 min	50 cycles	76 PCS	0/1
High Temperature Storage	Temp: 100 °C	1000 HRS	76 PCS	0/1
Low Temperature Storage	Temp: -55 °C	1000 HRS	76 PCS	0/1
DC Operating Life	Temp: 25 °C I _f =20mA	1000 HRS	76 PCS	0/1
High Temperature/ Higt Humidity	85 °C/ 85% RH	1000 HRS	76 PCS	0/1

FLASHING MODE

Seven Color(R,G,B,RG,GB,RB,RGB) Flash in turn; one fadeout, another fade-in at one time.

TYPICAL ELECTRICAL-OPTICAL CHARACTERISTICS CURVES

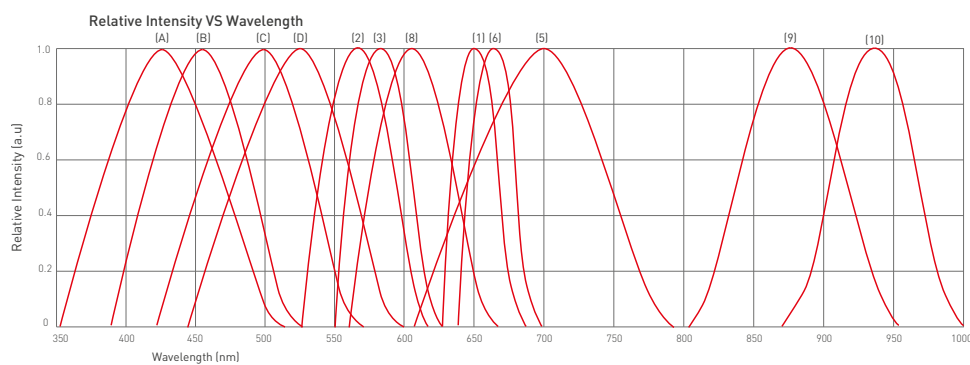

- (1) GaAsP/GaAs 655nm/Red
- (2) Gap 568nm/Yellow Green
- (3) GaAsP/Gap585nm Yellow
- (4) GaAsP/Gap 635nm/ Hi-Eff Red
- (5) Gap 700nm/ Bright Red
- (6) GaAlAs/GaAs 660nm/ Super Red
- (8) GaAsP/GaP 610nm/ Orange
- (9) GaAlAs 880nm
- (10) GaAs/GaAs&GaAlAs/GaAs 940nm
- (A) GaN 430nm/Blue
- (B) InGaN 470nm/Blue
- (C) InGaN502nm/Bluish Green
- (D) InGaN525nm/Pure Green

